

# salton®

## Coffee Maker

1 cup



Instruction Booklet

Model: FC-1026

# IMPORTANT SAFEGUARDS

When using electrical appliances, basic safety precautions should always be followed including the following:

1. Read all instructions.
2. Do not touch hot surfaces. Use handles or knobs.
3. To protect against electrical hazards, do not immerse cord, plugs, or the appliance in water or other liquid.
4. Close supervision is necessary when any appliance is used by or near children.
5. Unplug from outlet when not in use and before cleaning. Allow to cool before putting on or taking off parts, and before cleaning the appliance.
6. Do not operate any appliance with a damaged cord or plug or after the appliance malfunctions, or has been damaged in any manner. Return appliance to Salton Canada for examination, repair or adjustment. See Warranty.
7. The use of accessories or attachments not recommended by Salton Canada may cause hazards.
8. Do not use outdoors.
9. Do not let cord hang over edge of table or counter, or touch hot surfaces.
10. Do not place on or near a hot gas or electric burner, or in a heated oven.
11. Always attach plug to appliance first, then plug cord into the wall outlet. To disconnect, turn any control to "OFF", then remove plug from wall outlet.
12. Extreme caution must be used when moving an appliance containing hot liquids.
13. This appliance is for Household Use Only. Do not use appliance for other than intended use.
14. Do not leave unit unattended while in use.

**SAVE THESE INSTRUCTIONS**  
HOUSEHOLD USE ONLY

## POLARIZED PLUG

This appliance has a polarized plug (one blade is wider than the other). To reduce the risk of electric shock, this plug will fit in a polarized outlet only one way. If the plug does not fit fully in the outlet, reverse the plug. If it still does not fit, contact a qualified electrician. Do not modify the plug in any way.

## DESCRIPTION OF PARTS

1. Water Reservoir Cover
2. Water Reservoir
3. Water Spreader
4. Permanent Filter
5. Illuminated On/Off Switch
6. Cup/Mug Rest

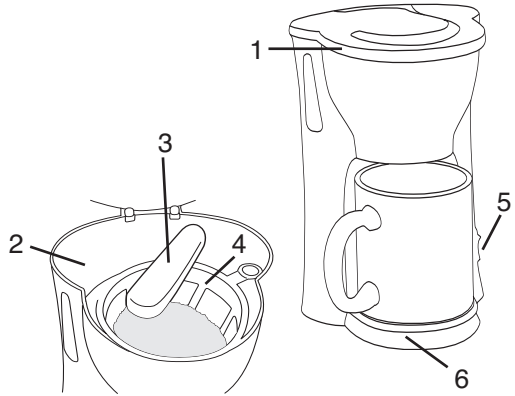

## BEFORE FIRST USE

1. Read all instructions carefully and keep them for future reference.
2. Remove all packaging.
3. Wash the Permanent Filter.
4. Follow the directions in the 'HOW TO USE' section, using water only.
5. Discard the water.

## HOW TO USE

### How to Brew Coffee

1. Fill your favorite cup/mug with fresh cold water. Pour into the Water Reservoir. **NOTE:** Minimum amount of water is 5 oz. (142 ml), maximum 10.5 oz. (300 ml). Please see the markings on the water level window for the maximum water capacity. Do not overfill.
2. Place the cup/mug on the Cup/Mug Rest.
3. Swivel the Water Spreader to the left. Fill the Permanent Coffee Filter with approximately 1 tbsp. (15 ml) or 1 scoop of filter coffee grounds for every 5 oz. (142 ml) of coffee. Return the Water Spreader to its original position.
4. Plug unit into a 120 Volt A.C. outlet.
5. Press the On/Off Switch to the "On" position.
6. Once the coffee has finished dripping into the mug, **press the On/Off Switch to the "Off" position.**
7. Unplug unit from outlet or follow directions above to prepare another cup of coffee. Be careful when opening the Reservoir Cover when the unit is hot.

### How to Heat Water for Tea, Hot Chocolate, etc.

1. Fill your favorite cup/mug with fresh cold water.
2. Pour into the Water Reservoir. **NOTE:** Minimum amount of water is 5 oz. (142 ml), maximum 10.5 oz. (300 ml).
3. Swivel the Water Spreader to the left and remove the Permanent Coffee Filter. Return Water Spreader to its original position.
4. Add tea bag, hot chocolate, or instant foods etc. to the cup/mug and place on the Cup/Mug Rest
5. Plug unit into a 120 Volt A.C. outlet.
6. Press the On/Off Switch to the "On" position.
7. **IMPORTANT:** Once the water has finished dripping into the mug, **press the On/Off Switch to the "Off" position.**
8. Unplug unit from outlet or follow directions above for more hot water. Be careful when opening the Reservoir Cover when the unit is hot.

## CARE AND CLEANING

1. Unplug unit and allow to cool.
2. Wipe Coffee Maker with a damp cloth. Do not use abrasive soapy or scouring pads.
3. NEVER IMMERSE THE COFFEE MAKER IN WATER OR ANY OTHER LIQUID.
4. The Cup/Mug Rest and Permanent Filter can be removed and washed in warm soapy water, rinsed and dried.

## Descaling

Under normal use, a deposit of scale may form on the inside of the Coffee Maker. This scale build up can clog the Coffee Maker. To remove scale follow the directions below:

1. Fill your cup/mug 2/3 full with white vinegar and then to the top with cold water.
2. Pour into the Water Reservoir. **NOTE:** Minimum amount of water is 5 oz. (142 ml), maximum 10.5 oz. (300 ml).
3. Place cup/mug on the Cup/Mug Rest.
4. Plug unit into a 120 Volt A.C. outlet.
5. Press the On/Off Switch to the "On" position.
6. **IMPORTANT:** Once the water has finished dripping into the mug, **press the On/Off Switch to the "Off" position.**
7. Unplug unit from outlet or if necessary, repeat the descaling directions above. Be careful when opening the Reservoir Cover when the unit is hot.
8. Wash the Permanent Filter in warm soapy water.

A short supply cord is provided to reduce the hazards of becoming entangled in or tripping over a long cord. Extension cords may be used if care is exercised in their use. If an extension cord is used, the marked electrical rating of the detachable power-supply cord or extension cord should be at least as great as the electrical rating of the appliance. If the appliance is of the grounded type, the extension cord should be of a grounded 3-wire cord. The extension cord should be arranged so that it will not drape over the counter top or table top, where it can be pulled on by children or tripped over.

## **LIMITED WARRANTY**

Salton Canada warrants that this appliance shall be free from defects in material and workmanship for a period of one year from the date of purchase. During this 'in-warranty' period, defective products will be repaired or replaced at the discretion of the retailer and/or Salton Canada. A defective product should be returned to the original place of purchase within the retailer's stipulated return/exchange period\*. If you are unable to have a defective product replaced under warranty by the retailer, Salton Canada will repair or replace the defective product without charge. You may contact us for assistance by mail, e-mail, fax or telephone as listed below.

This warranty covers normal domestic usage and does not cover damage which occurs in shipment or failure which results from alteration, accident, misuse, abuse, glass breakage, neglect, commercial use or improper maintenance.

To ensure prompt 'in-warranty' service be sure you have an original proof of purchase. You may be asked to return the product to us along with a description of the defect and your address, zip/postal code.

For repairs not covered by the warranty, please contact us for assistance.

# **salton**<sup>®</sup>

## **SALTON CANADA**

Customer Service Department

81A Brunswick

Dollard-des-Ormeaux

Quebec, Canada H9B 2J5

Website: [www.salton.com](http://www.salton.com)

E-mail: [service@salton.com](mailto:service@salton.com)

Fax: 514-685-8300

Tel: 514-685-3660

\* Return/exchange policies at each retailer vary and may differ from the Salton Canada 1 year limited warranty period.