



salton®

kettle & tea steeper



Instruction Booklet

Model GK1429

IMPORTANT SAFEGUARDS

When using electrical appliances, basic safety precautions should always be followed including the following:

1. Read all instructions.
2. **DO NOT** touch hot surfaces. Use handle only.
3. To protect against electrical hazards, do not immerse cord, plugs, base or the appliance in water or other liquid.
4. Close supervision is necessary when any appliance is used by or near children. Children should be supervised to ensure that they do not play with the appliance.
5. This appliance is not intended for use by persons (including children) with reduced physical, sensory or mental capabilities or lack of experience and knowledge, unless they have been given supervision or instruction concerning the use of the appliance by a person responsible for their safety.
6. If the Kettle is overfilled, boiling water may be ejected.
7. **WARNING:** Scalding may occur if the Lid is removed during the boiling cycle.
8. Unplug from outlet when not in use and before cleaning. Allow to cool before putting on or taking off parts, and before cleaning the appliance.
9. **DO NOT** operate any appliance with a damaged cord or plug or after the appliance malfunctions, or has been damaged in any manner. Return appliance to Salton for examination, repair or electrical or mechanical adjustment. All servicing other than cleaning should be performed by an authorized service representative. See Warranty section.
10. The use of accessories or attachments not recommended by Salton may result in fire, electric shock or personal injury.
11. **DO NOT** use outdoors.
12. **DO NOT** let cord hang over edge of table or counter, or touch hot surfaces.
13. **DO NOT** place on or near a hot gas or electric burner, or in a heated oven.
14. Always put Kettle on base then plug cord into the wall outlet. To disconnect, turn any control to 'OFF', then remove plug from wall outlet.
15. **DO NOT** use appliance for other than intended use.
16. **DO NOT** leave unit unattended while in use.
17. **DO NOT** plug an empty Kettle into the wall outlet.

18. **DO NOT** use the Kettle if the glass is cracked or has a loose or weakened handle.
19. Direct Kettle spout away from cabinets, walls, etc. to prevent possible steam damage.
20. Extreme caution must be used when moving an appliance containing hot liquids.



SAVE THESE INSTRUCTIONS

HOUSEHOLD USE ONLY

GROUNDING PLUG

To reduce the risk of electric shock this appliance has a grounded plug (2 blades and 1 pin). If the plug does not fit fully into the electrical outlet contact a qualified electrician. Do not modify the plug in any way or use an adaptor.

DESCRIPTION OF PARTS

1. Kettle Lid
2. Kettle Lid Release Button
3. Spout
4. Handle
5. Tea Infuser Assembly
 - a. Tea Infuser Plunger
 - b. Tea Infuser Basket Holder
 - c. Tea Infuser Basket
6. Base
 - a. 4 Preset Temperature Buttons
 - b. Keep Warm Button 
 - c. On/Off Button 
7. Cord Wrap

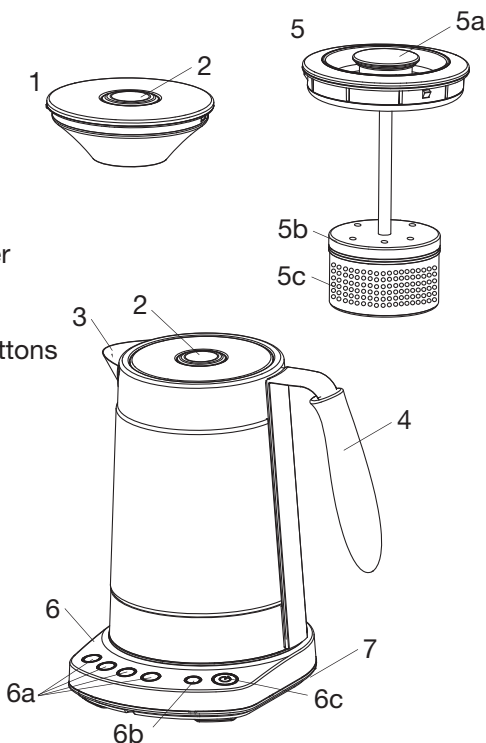

BEFORE FIRST USE

1. Read all instructions carefully and keep them for future reference.
2. Remove all packaging.
3. Gently wash the Tea Infuser Basket Holder and Basket.
4. Follow instructions in the How to Use the Kettle section below.
Water boiled for the first time should be discarded.

HOW TO USE THE KETTLE

1. Place the Kettle on a flat level surface close to a 120 volt A.C. outlet.
2. Press the Kettle Lid Release Button and lift the Kettle Lid to remove it from the Kettle.



3. Fill the Kettle with water between the MIN and 1.7L/Q MAX marking. **DO NOT** attempt to fill the Kettle while it is plugged into the wall outlet. **DO NOT** use the Kettle for anything other than boiling water or making tea. Other liquids will contaminate the interior of the Kettle. **DO NOT** fill past the MAX level indicated in the water level window. Overfilling may cause water to spit out when boiling.
4. Replace the Lid on the Kettle and gently press the Lid Release Button until it locks into place, flush with the Lid.
5. Place Kettle on the Base then plug into a 120V AC wall outlet.
NOTE:
 - Never plug Kettle into an electrical outlet when the Kettle is empty.
 - Direct Kettle Spout away from cabinets, walls, etc. to prevent possible steam damage.
6. Press the Preset Temperature Button that corresponds to the water temperature you desire. Press the On/Off Button to start the cycle. The blue lights around the chosen Preset Temperature Button will flash and the light around On/Off Button will light up and remain on. To quick start the Kettle press the On/Off Button and the Kettle will start the boil cycle at 100°C/212°F temperature.
NOTE: If you want to use the Keep Warm function follow the directions in the Keep Warm section.

7. The Kettle shuts off automatically and beeps twice when the cycle is complete. The light on the temperature button will remain on until you remove the Kettle from the Base.

NOTE: The Kettle will not beep when the boil cycle is complete if the Keep Warm function is used. The Preset Temperature Button will stop flashing when the boil cycle is complete.

8. To turn the Kettle off before the boiling cycle is complete, press the On/Off Button. The lights will go out.
9. If you want to use the Kettle again after completing a boiling cycle, allow the thermal safety switch to cool down for 15 – 20 seconds then select desired temperature and press the On/Off Button.

NOTE: If the selected temperature does not flash and the light around the On/Off Button does not come on, then the water is hot enough to use without reheating.

10. **IMPORTANT:**

- a. The Lid should never be opened when the Kettle is hot.
- b. Always keep the Lid on when pouring water.
- c. Only grip the Kettle by the Handle as all other surfaces will be hot.
- d. If the Kettle is accidentally switched on when empty, the thermostat will automatically cycle on and off to prevent the Kettle from overheating. If this situation occurs, press the On/Off switch and unplug the Kettle immediately. Let the Kettle cool before refilling.
- e. **DISCONNECT** the Power Cord from the wall outlet when not in use.

KEEP WARM FUNCTION

1. The Keep Warm function will keep water at the preset temperature for 30 minutes. This feature is only available in the 70°, 80° and 90°C (160°, 175° and 195°F) temperature settings.
2. To use the Keep Warm function press the Keep Warm Button () after you have selected a preset temperature and before you press the On/Off Button.
3. The light on the Keep Warm Button will light up when this function has been activated.
4. The Keep Warm function will remain active, even if the Kettle is removed from the Base, for a maximum of 1 minute.
5. **IMPORTANT: The Keep Warm Function cannot be used for the 100°C/212°F temperature.**

HOW TO USE THE TEA STEEPER

1. Use this function with the Tea Infuser Assembly.
2. Remove the Tea Infuser Basket by holding the Tea Infuser Basket Holder with one hand and turning the Basket counterclockwise.

3. Add tea leaves or tea bags to the Basket. The amount of tea should be based on the amount of water in the Kettle. **NOTE:** If you are using bagged tea the strings and tags can be removed.
4. Place the Basket back onto the Tea Infuser Assembly by turning clockwise.
5. Fill the Kettle with water between the MIN and the “TEA MAX THÉ” markings on the Kettle.
6. Insert the Tea Infuser Assembly in the raised position, into the Kettle.

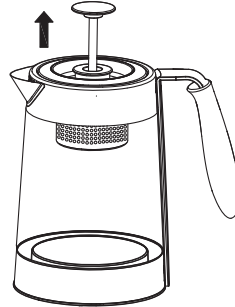

7. Place the Kettle on the Base.
8. Plug into a 120V AC wall outlet.

NOTE:

- Never plug Kettle into an electrical outlet when the Kettle is empty.
- Direct Kettle spout away from cabinets, walls, etc. to prevent possible steam damage.

9. Press the Preset Temperature Button that corresponds to the water temperature you desire. Press the On/Off Button to start the cycle. The blue lights around the chosen Preset Temperature Button will flash and the light around On/Off Button will light up and remain on. To quick start the Kettle press the On/Off Button and the Kettle will start the boil cycle at the 100°C/212°F temperature.

NOTE: If you want to use the Keep Warm function follow the directions in the Keep Warm section.

10. The Kettle shuts off automatically and will beep twice when the cycle is complete. The light on the temperature button will remain on until you remove the Kettle from the Base.

NOTE: The Kettle will not beep when the boil cycle is complete if the Keep Warm function is used. The preset temperature button will stop flashing when the boil cycle is complete.

11. Lower the Tea Infuser Basket once the water has reached the desired temperature and allow the tea to steep. **IMPORTANT:** The light around the Preset Temperature will remain on when the temperature is reached.
12. Follow the guide below for different tea steeping temperatures and time.

The following is a guide for brewing different types of tea. Brand and freshness of tea including each individuals taste and preference differs.

Type of Tea	Water Temperature	Steep Time
Green tea	70°C/160°F	1-3 minutes
White tea	80°C/175°F	4-8 minutes
Oolong tea	90°C/195°F	1-8 minutes
Black	100°C/212°F	3-5 minutes
Herbal tea	100°C/212°F	5-8 minutes

CARE AND CLEANING

1. Unplug power cord from wall outlet. Empty out remaining water and allow Kettle to cool before cleaning.
2. Under normal use, a deposit of scale may form on the inside of the Kettle and cause some discoloration. Scale, which has accumulated inside the Kettle, can be removed by boiling equal parts of white vinegar and water (500 ml / 2 cups of each is recommended). Once the water has boiled, allow mixture to stand several hours or overnight. Empty out mixture and fill Kettle to the MAX level with fresh water. Bring water to a boil and discard. For heavy scale build-up, repeat this process.
NOTE: This build-up can be delayed by pouring out old water and refilling before each use.
3. **DO NOT USE ABRASIVE CLEANERS.**
4. **DO NOT ALLOW WATER TO ENTER THE POWER BASE.**
5. **DO NOT IMMERSE KETTLE OR POWER BASE IN WATER OR OTHER LIQUID.**
6. **All servicing other than cleaning, should be performed by an authorized service representative. See Warranty section.**

A short supply cord is provided to reduce the hazards of becoming entangled in or tripping over a long cord. Extension cords may be used if care is exercised in their use. If an extension cord is used, the marked electrical rating of the detachable power-supply cord or extension cord should be at least as great as the electrical rating of the appliance. If the appliance is of the grounded type, the extension cord should be a grounded 3-wire cord. The extension cord should be arranged so that it will not drape over the counter top or table top, where it can be pulled on by children or tripped over.

LIMITED WARRANTY

The original sales receipt is the only acceptable proof of purchase

Salton Canada warrants that this appliance shall be free from defects in material and workmanship for a period of two (2) years from the date of original purchase. Salton Canada, at its sole discretion during this warranty period, will repair or replace a defective product or issue a refund. Any refund to the purchaser will be at a pro-rated value based on the remaining period of the warranty. All liability is limited to the amount of the purchase price. This warranty covers normal domestic usage and does not cover damage which occurs in shipment or failure which results from alteration, accident, misuse, abuse, glass breakage, neglect, improper maintenance, use contrary to the operating instructions or commercial use. This warranty is not available to retailers or other commercial purchasers or owners.

This warranty does not include the cost of shipping, which is to be borne by the customer.

TO OBTAIN PROMPT WARRANTY SERVICE:

Contact one of our many Service Centers found on our website
www.salton.com/customer-care

or

Securely package and return the appliance to us. Please enclose:

- Original proof of purchase
- The completed form below with a \$12.50 Return Shipping & Handling fee – either a cheque, money order or credit card (A personal cheque will delay return shipping by 2-3 weeks)

For added protection, we suggest that you use an insured delivery service with tracking information when returning your product. Salton Canada will not be held responsible for in-transit damage or for packages that are not received.

.....

Name _____

Address _____

City _____ Prov/State _____ Postal/Zip Code _____

Daytime Phone No. _____ Email _____

Product defect: _____

Type of payment Cheque/Money Order Visa MasterCard

Name on card _____ Expiry Date _____ CSV No _____

Card No. _____

To contact our Customer Service Department:

SALTON CANADA
81A Brunswick,
Dollard-des-Ormeaux, Quebec H9B 2J5
Canada

Telephone: 514-685-3660 (Ext. 226)
E-mail: service@salton.com
Fax: 514-685-8300
www.salton.com