



salton[®]
rotary
waffle maker



Instruction Booklet

Model WM1082

IMPORTANT SAFEGUARDS

When using electrical appliances, basic safety precautions should always be followed including the following:

1. Read all instructions.
2. **DO NOT** touch hot surfaces. Use handles or knobs.
3. To protect against electrical hazards, **DO NOT** immerse cord, plugs, or the appliance in water or other liquid.
4. Close supervision is necessary when any appliance is used by or near children.
5. Unplug from outlet when not in use and before cleaning. Allow to cool before putting on or taking off parts, and before cleaning the appliance.
6. **DO NOT** operate any appliance with a damaged cord or plug or after the appliance malfunctions, or has been damaged in any manner. Return appliance to Salton for examination, repair or adjustment. See Warranty.
7. The use of accessories or attachments not recommended by Salton may cause hazards.
8. **DO NOT** use outdoors.
9. **DO NOT** let cord hang over edge of table or counter, or touch hot surfaces.
10. **DO NOT** place on or near a hot gas or electric burner, or in a heated oven.
11. Extreme caution must be used when moving an appliance containing hot oil or other hot liquids.
12. **DO NOT** move the unit when it is still hot.
13. Prior to connecting or disconnecting plug from wall outlet, turn any control to 'Off'.
14. Always unplug appliance immediately after using. Allow to cool before cleaning and storing.
15. Always place appliance on a heat resistant surface.
16. **CAUTION:** This appliance generates heat during use. Proper precautions must be taken to prevent the risk of burns, fires or other damage to property caused by touching the sides or top while in use or during cooling.
17. **DO NOT** use appliance for other than intended use
18. **DO NOT** leave appliance unattended while in use.

SAVE THESE INSTRUCTIONS

HOUSEHOLD USE ONLY

GROUNDING PLUG

To reduce the risk of electric shock this appliance has a grounded plug (2 blades and 1 pin). If the plug does not fit fully into the electrical outlet contact a qualified electrician. Do not modify the plug in any way or use an adaptor.

DESCRIPTION OF PARTS

1. Folding Handle
2. Red Power Light
3. Green Ready Light
4. Temperature Control Knob
5. Removable Drip Tray
6. Base/Support

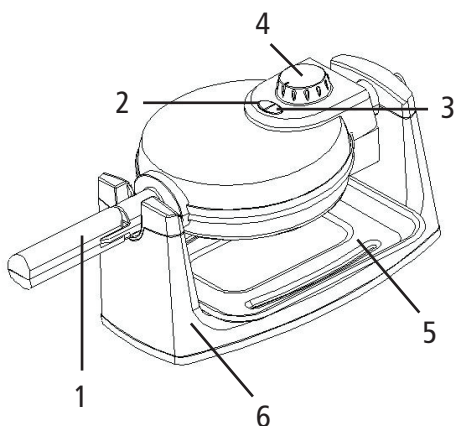

BEFORE FIRST USE

1. Read all instructions carefully and keep them for future reference.
2. Remove all packaging.
3. Clean the Cooking Plates by wiping with a sponge or cloth dampened in warm water. **DO NOT IMMERSE THE UNIT AND DO NOT RUN WATER DIRECTLY ONTO THE COOKING SURFACE.**
4. Dry with a cloth or paper towel.
5. Lightly coat the cooking plates with a little cooking oil or a cooking spray.

HOW TO USE

1. Plug unit into a 120V AC outlet. The red power light will come on, as well as the green ready light if the Temperature Control Dial is in the '0' position.
2. Set the temperature control knob to the desired setting: low for light colored waffles and up to MAX for darker, crispier waffles. The green ready light will go off.
3. Close the lid until it is preheated and the green ready light comes on.
4. Open the lid and pour batter to fill the lower cooking plate. If necessary, use a spatula to spread the batter to the edges of the cooking plate.
5. Close the lid. The green ready light will now cycle on and off to maintain the preset temperature.
6. Steam will escape from the waffle maker as the waffle is cooking.
7. Rotate the unit 180° to the right (clockwise). NOTE: do not open for at least 1 1/2 minutes. Opening too soon will cause under-baked waffles to split, making them difficult to remove.
8. The waffle is done when there is no more steam escaping from the waffle maker. Rotate the waffle maker 180° to the left (counterclockwise) to check the waffle. For a darker waffle, close the lid and continue baking until the desired color is achieved.
9. Once the waffles are cooked, carefully remove them from the waffle maker with a wooden or plastic spatula. Never touch the cooking surface with sharp, pointy or metal objects. This could damage the non-stick surface.
10. To cook more waffles, close the unit to retain heat and make sure the green light comes on before pouring the batter onto the cooking grid. Follow the directions above.
11. Once you are finished cooking, disconnect the plug from the wall outlet and leave unit open to cool.

HELPFUL HINTS

1. Do not over mix batter or waffles will be tough. Stir batter only until large lumps of dry ingredients disappear. The amount of batter required varies between 3/4 and 1 cup.
2. To retain crispness, let the baked waffle cool on a wire rack to prevent steam from accumulating underneath.
3. Cooled waffles can be re-warmed by returning them to the hot waffle maker. Set the temperature control knob to low, place the waffle on the grid, close the lid and heat for 1 to 2 minutes, watching carefully to prevent burning.
4. The Belgian Waffle Maker has a non-stick surface for even baking and easy cleaning.
5. Waffles can be baked ahead of time. Prepare according to the recipes and cool on a rack for approximately 10 minutes. Store in your freezer for up to 2 weeks. Waffles can be heated by toasting in a toaster or toaster oven.
6. Unused batter can be stored in the refrigerator for up to 3 days.

CARE AND CLEANING

1. Unplug the Waffle Maker and allow it to cool.
2. Wipe the Cooking Plates with a cloth dampened with warm soapy water. **DO NOT IMMERSE THE UNIT AND DO NOT RUN WATER DIRECTLY ONTO THE COOKING PLATES.**
3. Dry the cooking plates with a cloth or paper towel.
4. Do not use steel wool pads or other abrasive cleansers on the Cooking Plates as they may damage the non-stick coating.
5. If batter has adhered to the Cooking Plates, pour a small amount of cooking oil onto the baked-on food and allow to stand for 5 – 10 minutes. Wipe with paper towels.
6. Wipe the outside of the Waffle Maker with a soft cloth dampened in warm soapy water. Do not use scouring pads or steel wool.
7. Rinse with a dampened clean cloth. Dry.

RECIPES

Basic Waffle Recipe

2 cups (500 ml) all purpose flour

1 tsp. (5 ml) baking soda

1/4 tsp. (1.5 ml) salt

2 tbsp. (30 ml) sugar

Mix in separate bowl:

2 egg yolks, beaten

2 cups (500 ml) milk

1/3 cup (85 ml) melted butter

Separately:

Beat 2 egg whites into peaks until stiff but not dry.

Make a well in the dry ingredients and add milk and egg mixture. Combine with a few swift strokes -- batter will be slightly lumpy. Fold in beaten egg whites until just combined. Follow directions in the 'How to Use' section.

Makes 16 waffles

Quick Waffles

2 eggs

3/4 cup (180 ml) milk

2 tbsps. (30 ml) vegetable oil

1 cup (250 ml) flour

1 1/2 tsps. (8 ml) baking powder

1 1/2 tsps. (8 ml) sugar

1/2 tsp (3 ml) salt

In medium bowl, beat eggs until thick, add milk and oil. Add dry ingredients, mix until smooth. Follow directions in the 'How to Use' section.

Buttermilk Waffles

Sift together into large bowl:

2 cups (500 ml) all purpose flour

1 tsp. (5 ml) baking soda

1/4 tsp. (1,5 ml) salt

2 tbsps. (30 ml) (packed) light brown sugar

1/4 tsp. (1,5 ml) cinnamon

Mix in separate bowl:

2 egg yolks, beaten

2 cups (500 ml) buttermilk

1/3 cup (85 ml) melted butter

Separately

Beat 2 egg whites into peaks, until stiff but not dry

Make a well in the dry ingredients, and add buttermilk and egg mixture. Combine with a few swift strokes -- batter will be slightly lumpy. Fold in beaten egg whites until just combined. Follow directions in the 'How to Use' section.

Makes approximately 14 waffles

Egg Waffles

2/3 cup (170 ml) plain flour

1/4 cup (65 ml) water

4 eggs, separated

1/2 tsp. (3 ml) salt

2 1/2 tbsps. (37 ml) melted butter or bacon fat

pinch of black pepper

Blend the flour and water together. In a separate bowl, beat the egg yolks until pale yellow. Add to the flour and water mixture. Stir in the salt, pepper and melted butter or bacon fat. Set aside and allow to stand for at least an hour. Beat the egg whites until stiff and gently fold into the batter.

Follow directions in the 'How to Use' section.

Makes 2-4 waffles

Dessert Waffles

- 1 cup (250 ml) cake flour
- 1/2 tsp. (3 ml) salt
- 1 tbsp. (15 ml) baking powder
- 2 1/2 tbsp. (37 ml) sugar
- 2 eggs
- 1 cup (250 ml) cream
- 2 egg whites

Sift together the flour, salt, baking powder and sugar into a mixing bowl.

Beat the two eggs until they are pale yellow then add the cream and mix thoroughly. Beat the egg mixture into the flour mixture until smooth. Set aside for at least one hour. Beat the egg whites until stiff and fold into the batter. Follow directions in the 'How to Use' section.

Makes 4-8 waffles

Pre-Packaged Pancake Mix Waffles

Standard pre-packaged pancake mixes can also be used in the Waffle Maker.

Mix:

- 2 eggs
- 2 1/2 cups (625 ml) "pancake mix"
- 2 cups (500 ml) milk
- 1/3 cup (85 ml) melted butter or vegetable oil

Follow directions in the 'How to Use' section.

A short supply cord is provided to reduce the hazards of becoming entangled in or tripping over a long cord. Extension cords may be used if care is exercised in their use. If an extension cord is used, the marked electrical rating of the detachable power-supply cord or extension cord should be at least as great as the electrical rating of the appliance. If the appliance is of the grounded type, the extension cord should be a grounded 3-wire cord. The extension cord should be arranged so that it will not drape over the counter top or table top, where it can be pulled on by children or tripped over.

LIMITED WARRANTY

****The original sales receipt is the only acceptable proof of purchase****

Salton Canada warrants that this appliance shall be free from defects in material and workmanship for a period of two (2) years from the date of original purchase. Salton Canada, at its sole discretion during this warranty period, will repair or replace a defective product or issue a refund. Any refund to the purchaser will be at a pro-rated value based on the remaining period of the warranty. All liability is limited to the amount of the purchase price. This warranty covers normal domestic usage and does not cover damage which occurs in shipment or failure which results from alteration, accident, misuse, abuse, glass breakage, neglect, improper maintenance, use contrary to the operating instructions or commercial use. This warranty is not available to retailers or other commercial purchasers or owners.

This warranty does not include the cost of shipping, which is to be borne by the customer.

TO OBTAIN PROMPT WARRANTY SERVICE:

Contact one of our many Service Centers found on our website
www.salton.com/customer-care

or

Securely package and return the appliance to us. Please enclose:

- Original proof of purchase
- The completed form below with a \$12.50 Return Shipping & Handling fee – either a cheque, money order or credit card (A personal cheque will delay return shipping by 2-3 weeks)

For added protection, we suggest that you use an insured delivery service with tracking information when returning your product. Salton Canada will not be held responsible for in-transit damage or for packages that are not received.

This warranty does not include the cost of shipping, which is to be borne by the customer.

.....
Name _____

Address _____

City _____ Prov/State _____ Postal/Zip Code _____

Daytime Phone No. _____ Email _____

Product defect: _____

Type of payment Cheque/Money Order Visa MasterCard

Name on card _____ Expiry Date _____ CSV No _____

Card No. _____

To contact our Customer Service Department:

SALTON CANADA
81A Brunswick,
Dollard-des-Ormeaux, Quebec H9B 2J5
Canada

Telephone: 514-685-3660 (Ext. 226)
E-mail: service@salton.com
Fax: 514-685-8300
www.salton.com