



**salton®**  
**VitaPro™plus**  
low speed **juicer &**  
**smoothie maker**



**Instruction Booklet**  
Model JE1372PL

# IMPORTANT SAFEGUARDS

When using electrical appliances, basic safety precautions should always be followed including the following:

1. Read all instructions.
2. Always use this appliance on a dry, level surface.
3. To protect against electrical hazards, do not immerse cord, plugs, or the appliance in water or other liquid. Do not place on a wet surface.
4. Close supervision is necessary when any appliance is used by or near children. Children should be supervised to ensure that they do not play with the appliance.
5. This appliance is not intended for use by persons (including children) with reduced physical, sensory or mental capabilities or lack of experience and knowledge, unless they have been given supervision or instruction concerning the use of the appliance by a person responsible for their safety.
6. Unplug from outlet when not in use, before putting on or taking off parts and before cleaning.
7. Do not operate any appliance with a damaged cord or plug or after the appliance malfunctions, or is dropped or damaged in any manner. Return appliance to Salton for examination, repair or electrical or mechanical adjustment. See Warranty.
8. The use of accessories or attachments not recommended or sold by Salton may cause fire, electric shock or injury.
9. Do not use outdoors.
10. Do not let cord hang over edge of table or counter, or touch hot surfaces.
11. Extreme caution must be used when moving an appliance containing hot liquids.
12. This appliance is for Household Use Only.
13. Do not use appliance for other than intended use.
14. Do not leave unit unattended while in use.
15. Always turn the appliance off and unplug from the outlet when left unattended or finished using.
16. Check to be sure that the switch is in the OFF position after each use. Ensure that the motor is stopped before disassembling.
17. Avoid contacting moving parts. Make sure that the motor stops completely before disassembling.
18. Always make sure the juicer is fully assembled and the juicer cover is locked securely in position before the motor is turned on. Do not attempt to remove parts when the juicer is in operation.
19. Do not either operate or plug and unplug the unit with wet hands.
20. Do not use the appliance continuously for more than 30 minutes.
21. Do not turn the appliance on for more than 2 minutes without adding food. This may damage the auger.
22. Do not use this appliance if the strainer basket is damaged.
23. Do not put your fingers or other objects into the food chute while it is operating. Always use the food pusher provided.
24. During operation feed the food slowly to avoid clogging. If the unit gets clogged turn the appliance off immediately. Press the reverse function on the on/off switch. If this does not work, press the on/off switch to the off position, unplug the appliance, remove the cover and remove the stuck food.
25. Cut ingredients into small pieces and take out the core as it may cause a blockage.

- 26. Do not place on or near a hot gas or electric burner, or in a heated oven.
- 27. Always attach plug to appliance first, then plug cord into the wall outlet. To disconnect, turn any control to 'OFF', then remove plug from wall outlet.
- 28. Do not attempt to override the safety features.

# SAVE THESE INSTRUCTIONS

## HOUSEHOLD USE ONLY

### POLARIZED PLUG

This appliance has a polarized plug (one blade is wider than the other). To reduce the risk of electric shock, this plug will fit in a polarized outlet only one way. If the plug does not fit fully in the outlet, reverse the plug. If it still does not fit, contact a qualified electrician. Do not modify the plug in any way.

### How does the VitaPro Juicer Work

The VitaPro Juicer is a juice extractor that uses low speed technology. It is called low speed because it operates at only 80 – 90 RPM. The VitaPro actually juices faster than a typical juicer and expels a much drier pulp with a much higher yield. An auger extracts the juice by masticating and slowly squeezing like a mortar & pestle compared to 1,000 to 24,000 RMP's in the typical centrifuge juicer, which cuts and damages the food. The low speed action crushes and squeezes the food releasing the deep-seated nutrients and enzymes. It also breaks up more of the phytonutrients and results in a richer coloured juice that retains more vitamins and minerals. The slower RPM's ensures that it does not disturb the cellular structure of fruits and vegetables, reducing oxidation and juice separation and preserving the enzymes and nutrients of the food that are in its natural form.

### DESCRIPTION OF PARTS

- 1. Cover
- 2. Food Chute
- 3. Pulp Chute
- 4. Spout with Cover
- 5. Food Tray
- 6. Food Pusher
- 7. Sweeper Basket (1)
- 8. Juice Strainer
- 9. Smoothie Strainer
- 10. Auger
- 11. Juice Bowl
- 12. Main Housing
- 13. Containers (2)
- 14. Cleaning Brush

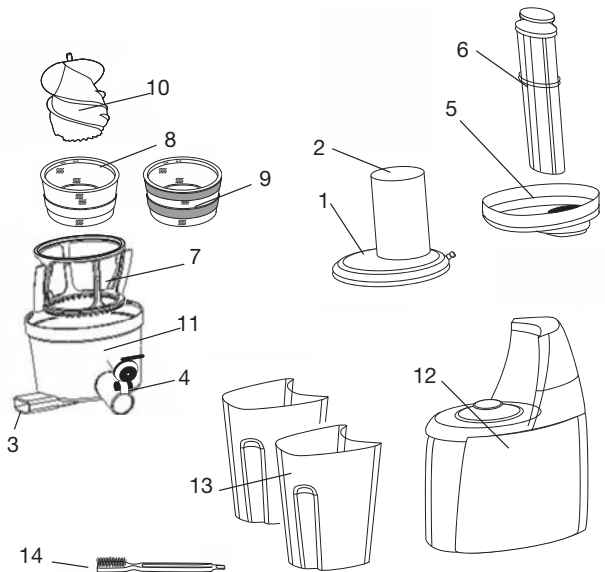

## BEFORE FIRST USE

1. Carefully unpack the VitaPro Juicer
2. Follow the disassembly instructions.
3. Wash all the removable parts including the Cover, Food Pusher, Sweeper Basket, Juice and Smoothie Strainers, Auger and Juice Bowl in warm soapy water. Rinse and dry.

**NOTE:** Use care when handling the Strainers. Hold by the rim only to avoid damaging the delicate stainless steel foil.

## DISASSEMBLING THE VITAPRO JUICER

1. Remove the Cover by turning it counterclockwise until the tab on the Cover releases from the slot in the main housing.
2. Turn Juice Bowl counterclockwise to the unlock position and lift from the main housing.
3. Place on flat surface. While holding bowl with one hand lift Strainer with other parts out of Juice Bowl. Disassemble.

## ASSEMBLING THE VITAPRO JUICER

1. Assemble the Juice Bowl on the Base by lining up the 2 unlock arrows. There is one arrow on the main housing and one on the Juice Bowl.

Turn the Bowl clockwise so that its arrow is aligned with the “locked” arrow on the main housing.

2. Place the Sweeper Basket inside the Juice Bowl.
3. Place either the Juice Strainer or the Smoothie Strainer inside the Juice Bowl so that the red dot on the Strainer lines up with the red dot on the Juice Bowl.
4. Place the Auger in the center of the Juice Bowl. Gently push the Auger down and twist until you hear it click into position.
5. Place the Cover onto the Juice Bowl. **IMPORTANT: Line up the grey dot on the Cover with the red dot on the Juice Bowl.** Turn the Cover clockwise until the arrow on the Cover is PERFECTLY lined up with the arrow printed on the Main Housing.

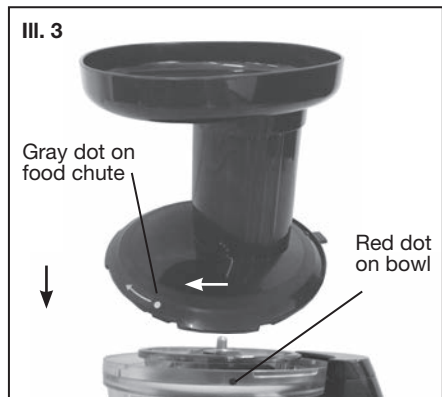
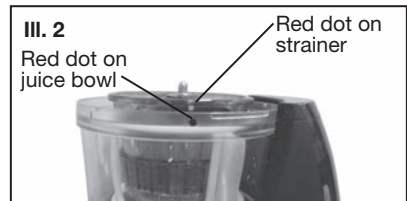
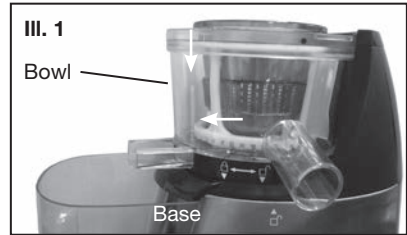

## HOW TO USE

1. Ensure that all parts are securely in place then plug into the wall outlet.
2. Place one Container under the Pulp Chute and one of the containers or a glass under the Juice Spout.
3. There are three settings on the Switch:  
ON – Starts the motor for juicing  
OFF – Stops the motor and operation  
REVERSE – Moves the Auger in the opposite direction.



## JUICING

1. Wash all food to be juiced. Cut into appropriate size pieces to easily fit into the Food Chute. Remove and discard any hard seeds, pits or unwanted sections before juicing.  
NOTE:  
(a) When making carrot juice the length should be no more than 80mm (3”), width 15mm (1/2”). Feed at intervals of 5 seconds.  
(b) Do not put frozen fruit, vegetables or ice into the unit.
2. Place food into the Food Chute and the Juicer will pull in the food and start juicing immediately. Use the Food Pusher if necessary to dislodge food that is stuck in the Food Chute. NOTE: Do not allow the VitaPro Juicer to run longer than 2 minutes without adding food.  
**IMPORTANT:** Never place your fingers in the Food Chute.
3. For best results insert food slowly to allow pulp to be extracted. Do not over stuff or rush the juicing process.
4. The VitaPro Juicer has a unique simple rinsing process to switch between different kinds of juice. Simply pour water through the Food Chute. This will rinse out most of the residue and you are ready to keep juicing.
5. When you have completed juicing turn the unit to the OFF position, unplug from the wall outlet and follow the directions in the Care and Cleaning section.

## SMOOTHIES

1. The smoothie strainer can be used with both fresh and frozen fruit.
2. Salton recommends that you use berries, peaches, nectarines, bananas, papaya, mango and other fruits that do not contain seeds.
3. Use approximately 2 cups (500 ml) of fruit to 1 cup (250 ml) of liquid. Adjust the ratio of fruit to liquid depending on the smoothie thickness you prefer.
4. Mix fruit with milk, juice or other liquid.
5. Close the spout cover.
6. Place one container under the pulp chute and the other under the juice spout.
7. Turn on the Juicer. NOTE: Do not allow the Juicer to run without food for more than a few seconds.
8. Pour the fruit/liquid mixture into the Food Chute. Push the mixture down with the Food Pusher, if necessary. NOTE: It is possible that a small amount of the liquid may come out of the pulp chute.
9. Allow the Juicer to work for 2 – 3 minutes.
10. Open the spout cover and collect the smoothie in the provided container or a glass.

**IMPORTANT NOTE:** Never use ice in the appliance this will damage the auger.

## CARE AND CLEANING

1. Follow the directions in the 'Disassembling the VitaPro Juicer'.
2. Using the Cleaning Brush provided, clean the Strainers. Hold by the top rim only and use the brush to clean the mesh.
3. Wash the other disassembled parts in warm soapy water. Do not use abrasive cloths or cleansers.  
NOTE: There is a silicone pad under the Juice Bowl that prevents juice from exiting through the pulp ejector. When using the VitaPro Juicer ensure that the silicone pad is firmly in place in the slot. You may slide the pad out and use the opposite end of the Cleaning Brush if food is caught in the slot.
4. Wipe the Main Housing of the VitaPro Juicer with a damp cloth. **NEVER IMMERSE THE MAIN HOUSING OR PLUG IN WATER OR ANY OTHER LIQUID.**
5. Dry all parts thoroughly before assembling the VitaPro Juicer.
6. Cleaning the Juicer immediately after each use will reduce the stains on the Juice Bowl, Sweeper, and Cover but carrots or other strong colours in food may still stain the Juicer. We suggest using one of the following cleaning procedures:
  - a) Soak in mild soapy water
  - b) Equal parts warm water to cider vinegar
  - c) Soak in ½ box of baking soda and warm water
  - d) ½ cup bleach in a sink full of warm water

## TROUBLESHOOTING

PROBLEM	SOLUTION
Appliance does not operate	<ul style="list-style-type: none"><li>• Check power cord and power source.</li><li>• Check the Assembly section to ensure that all parts have been assembled correctly.</li></ul>
Appliance jams/clogs or stops operating	<ul style="list-style-type: none"><li>• Check for a blockage in the food chute.</li><li>• Look in the food chute to see if pits or hard seeds are stuck in the appliance.</li><li>• Turn the appliance off then switch to reverse for 3 seconds.</li><li>• Disassemble the upper section and clear the remaining pulp. NOTE: do not remove the cover until the appliance has been unplugged from the wall outlet.</li></ul>
Squeaking noise when juicing	<ul style="list-style-type: none"><li>• This is normal.</li></ul> NOTE: The juicer should not be run without food.
Leaking from underneath the juice bowl	<ul style="list-style-type: none"><li>• Ensure that the silicone pad is tightly in place after cleaning.</li></ul>
Strainer Damage	<ul style="list-style-type: none"><li>• Contact our service department.</li></ul>
Too much pulp	<ul style="list-style-type: none"><li>• Cut food into smaller pieces, especially foods with a lot of fibre.</li><li>• Insert food at a slower pace and allow food pulp to eject from the unit before adding more food.</li></ul>
Bowl is stuck and will not detach from the base	<ul style="list-style-type: none"><li>• This is caused by excess food in the bowl. Press the reverse button for 3 -5 seconds. Repeat this 2 or 3 times. Push the bowl upward when turning.</li></ul>
Cover is stuck	<ul style="list-style-type: none"><li>• Press the reverse button for 3 – 5 seconds. Repeat 2 – 3 times. Press down on Cover while turning.</li></ul>

## JUICER RECIPES

Below are a few juice recipes for your convenience. Additional recipes are available on the internet. Recipe books are also available at your local bookstore.

Follow the directions in the **How to Use** section.

### **Apple Strawberry**

5 apples

1 cup strawberries

Alternate juicing apples and strawberries.

### **Apple Veggie Juice**

2 apples

3 carrots

1 stalk celery

Alternate juicing apples, carrots and celery.

### **Vegetable Juice**

4 carrots

2 ozs. (100 g) spinach

Small handful of flat leaf parsley

2 stalks celery

Alternate juicing above

ingredients.

### **Fruit & Vegetable Cocktail**

1/2 pineapple, peeled

1 carrot

1 apple

1 stalk celery

Process ingredients through the juicer.

### **Peach, Pear and Apple Juice**

1 apple

2 peaches, seed removed

1 pear

Process ingredients through the juicer.

## SMOOTHIE RECIPES

### **Berry Smoothie**

1 cup (250 ml) milk

1/2 cup (125 ml) frozen raspberries

1/2 cup (125 ml) frozen blackberries

1 cup (250 ml) frozen strawberries

Follow the directions in the HOW TO USE/Smoothie section.

### **Tropical Smoothie**

2/3 cup (170 ml)      milk  
1/3 cup (85 ml)        plain yogurt  
1-1/2 cups (375 ml)   frozen mango  
1/2                        banana

Follow the directions in the HOW TO USE/Smoothie section.

### **Strawberry Banana Smoothie**

1 cup (250 ml)        strawberries  
1 med.                 banana  
3/4 cup (180 ml)      orange juice

Follow the directions in the HOW TO USE/Smoothie section.

### **Pina Colada Smoothie**

1 cup (250 ml)        frozen pineapple  
1 medium              banana  
1/2 cup (125 ml)      unsweetened coconut milk  
1/2 cup (125 ml)      pineapple juice

Follow the directions in the HOW TO USE/Smoothie section.

### **Peach Yogurt Smoothie**

2 cups (500 ml)        sliced fresh peaches (not canned)  
3/4 cup (180 ml)      plain or peach yogurt  
1/4 cup (60 ml)        milk  
Dash                    cinnamon

Follow the directions in the HOW TO USE/Smoothie section.

### **Blueberry Smoothie**

3/4 cup (180 ml)      frozen pineapple  
1-1/4 cups (310 ml)   frozen blueberries  
1 cup (250 ml)        orange juice

Sweeten with honey if desired.

Follow the directions in the HOW TO USE/Smoothie section.



A short supply cord is provided to reduce the hazards of becoming entangled in or tripping over a long cord. Extension cords may be used if care is exercised in their use. If an extension cord is used, the marked electrical rating of the detachable power-supply cord or extension cord should be at least as great as the electrical rating of the appliance. If the appliance is of the grounded type, the extension cord should be a grounded 3-wire cord. The extension cord should be arranged so that it will not drape over the counter top or table top, where it can be pulled on by children or tripped over.

**LIMITED WARRANTY**

**\*\*The original sales receipt is the only acceptable proof of purchase\*\***

Salton Canada warrants that this appliance shall be free from defects in material and workmanship for a period of five (5) years from the date of original purchase. Salton Canada, at its sole discretion during this warranty period, will repair or replace a defective product or issue a refund. Any refund to the purchaser will be at a pro-rated value based on the remaining period of the warranty. All liability is limited to the amount of the purchase price. This warranty covers normal domestic usage and does not cover damage which occurs in shipment or failure which results from alteration, accident, misuse, abuse, glass breakage, neglect, improper maintenance, use contrary to the operating instructions or commercial use. This warranty is not available to retailers or other commercial purchasers or owners.

This warranty does not include the cost of shipping, which is to be borne by the customer.

**TO OBTAIN PROMPT WARRANTY SERVICE:**

Contact one of our many Service Centers found on our website  
www.salton.com/customer-care

or

Securely package and return the appliance to us. Please enclose:

- Original proof of purchase
- The completed form below with a \$12.50 Return Shipping & Handling fee – either a cheque, money order or credit card (A personal cheque will delay return shipping by 2-3 weeks)

For added protection, we suggest that you use an insured delivery service with tracking information when returning your product. Salton Canada will not be held responsible for in-transit damage or for packages that are not received.

This warranty does not include the cost of shipping, which is to be borne by the customer.

Name \_\_\_\_\_

Address \_\_\_\_\_

City \_\_\_\_\_ Prov/State \_\_\_\_\_ Postal/Zip Code \_\_\_\_\_

Daytime Phone No. \_\_\_\_\_ Email \_\_\_\_\_

Product defect: \_\_\_\_\_

Type of payment      Cheque/Money Order       Visa       MasterCard

Name on card \_\_\_\_\_ Expiry Date \_\_\_\_\_ CSV No \_\_\_\_\_

Card No. \_\_\_\_\_

To contact our Customer Service Department:

SALTON CANADA  
81A Brunswick,  
Dollard-des-Ormeaux, Quebec H9B 2J5  
Canada

Telephone: 514-685-3660 (Ext. 226)  
E-mail: service@salton.com  
Fax: 514-685-8300  
www.salton.com