

salton®

Pizza Oven



Model: PO-1009

IMPORTANT SAFEGUARDS

When using electrical appliances, basic safety precautions should always be followed including the following:

1. Read all instructions.
2. Do not touch hot surfaces. Use handles or knobs.
3. To protect against electrical hazards, do not immerse cord, plugs, or the appliance in water or other liquid.
4. Close supervision is necessary when any appliance is used by or near children.
5. Unplug from outlet when not in use and before cleaning. Allow to cool before putting on or taking off parts, and before cleaning the appliance.
6. Do not operate any appliance with a damaged cord or plug or after the appliance malfunctions, or has been damaged in any manner. Return appliance to Salton for examination, repair or adjustment. See Warranty.
7. The use of accessories or attachments not recommended by Salton may cause fire, electric shock or injury.
8. Do not use outdoors.
9. Do not let cord hang over edge of table or counter, or touch hot surfaces.
10. Do not place on or near a hot gas or electric burner, or in a heated oven.
11. Extreme caution must be used when moving an appliance containing hot oil or other hot liquids.
12. Always attach plug to appliance first, then plug cord into the wall outlet. To disconnect, turn any control to 'OFF', then remove plug from wall outlet.
13. Do not use appliance for other than intended use.
14. Do not insert oversized foods or utensils into the oven as they may create a fire or risk of electric shock.
15. Do not place paper, cardboard, plastic and the like in the oven.
16. Do not cover the Crumb Tray or any part of the Oven with metal foil; this can cause overheating of the Oven.
17. Do not clean with metal scouring pads. Pieces can break off the pad and touch electrical parts, creating a risk of electrical shock.
18. Do not store any materials other than manufacturer recommended accessories in the Oven when not in use.
19. A fire may occur if this Oven is covered by or touches flammable material, including curtains, draperies, walls, etc when in operation. Do not store any item on top of the appliance when in operation.
20. The oven can be turned off while using any of the functions by turning the Timer Knob to the Off position.

SAVE THESE INSTRUCTIONS
HOUSEHOLD USE ONLY

GROUNDING PLUG

To reduce the risk of electric shock this appliance has a grounded plug. (2 blades and 1 pin) If the plug does not fit fully into the electrical outlet contact a qualified electrician. Do not modify the plug in any way or use an adaptor.

DESCRIPTION OF PARTS

1. Top Heating Elements
2. Bottom Heating Elements
3. Temperature Control
4. Timer
5. Indicator Light
6. Wire Rack
7. Wire Rack Hook
8. Crumb Tray
9. Rack Handle

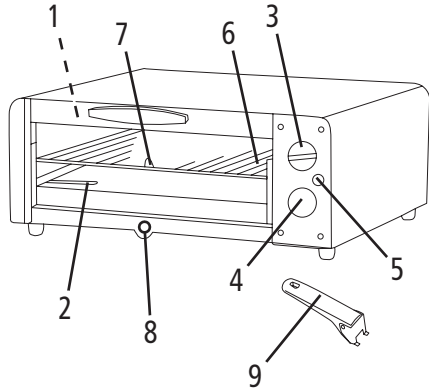

BEFORE FIRST USE

1. Remove all accessories and shipping materials packed inside the Oven.
2. Wash the Wire Rack and Crumb Tray in warm soapy water. Wipe the inside of the Oven with a damp cloth or sponge. Blot dry with paper towels to be sure the unit is dry before using.
3. Place the Oven on a flat counter or other stable surface, close to a 120 volt wall outlet. **DO NOT OPERATE ON THE SAME CIRCUIT WITH ANOTHER APPLIANCE.**
4. Position the Oven so that it is at least 2 inches (5 cm) from any surrounding object. Ensure that nothing has been placed on top of the Oven.
5. The Crumb Tray must be installed before using. Close the Glass Door and slide the Crumb Tray into the slot under the oven cavity.
6. For the first time only, turn the Temperature Control Dial to 400°F (200°C) and the Timer dial to 15 minutes. This will burn off any manufacturing oils still on the Oven. **NOTE: The Oven may smoke during this process. This is normal for a new Oven and will not last more than 10 – 15 minutes.**

HOW TO USE

1. Place the Oven on a flat counter or other stable surface, close to a 120 volt wall outlet. **DO NOT OPERATE ON THE SAME CIRCUIT WITH ANOTHER APPLIANCE.** Ensure that the Timer is in the off position, then plug into the wall outlet.
2. Position the Oven so that it is at least 2 inches (5 cm) from any surrounding object. Ensure that nothing has been placed on top of the Oven.
3. Ensure that the Crumb Tray is properly installed before using.
4. Install the Wire Rack so that the hook on the Rack is placed at the front of the Oven and facing upward.
5. Pre-heating is not required. Set the temperature according to the recipe or package directions by turning the Temperature Control Knob clockwise. Pull out the rack and place the pizza on the Rack. Push the Rack back into the Oven. Close the glass door and set the Timer to the required amount of time. The pizza should be watched to prevent overcooking.
6. When the preset time has elapsed the Timer bell will sound.
NOTE: If the pizza is cooked before the time has elapsed, turn the Timer counterclockwise to the '0' (Off) position.
7. Remove the pizza by pulling out the Rack with the Rack Handle. Place the Rack Handle metal bracket so that the bracket tabs fit under the Wire Rack and the bracket groove fits over Wire Rack Hook. Slowly straighten the Handle and pull out the Wire Rack.
NOTE: Use oven mitts when removing the pizza from the oven. All parts of the Oven will be hot.

CARE AND CLEANING

1. Turn the Timer Knob to the '0' (Off) position.
2. Unplug from the wall outlet and let the Oven cool completely.
3. Remove the Wire Rack and Crumb Tray and wash in warm soapy water. Rinse and dry.
4. Wipe the outside of the oven and the glass door with a dampened cloth or sponge. Never use sharp utensils to clean the Glass Door as scratching may weaken it and cause it to shatter. **NEVER IMMERSER THE PIZZA OVEN IN WATER OR ANY OTHER LIQUID.**

RECIPES

Homemade pizza usually cooks in 20 – 25 minutes at the maximum temperature. Frozen pizza usually cooks in 10 – 12 minutes at the maximum temperature. These are only suggested times. The pizza should be watched to prevent overcooking.

NOTE: When making home-made pizza, place the dough on a cookie sheet or pizza peel so that the pizza can easily be transferred to the Wire Rack. Shape the outside edge of the dough by folding over so ingredients do not leak off the edge of the pizza when cooking.

Basic Pizza Crust

1 tbsp (15 ml)	Sugar
1 pkg.	Active dry yeast
1 cup (250 ml)	Warm water (105-115°F/40-45°C)
3 cups (750 ml)	All-purpose flour, divided
1/4 tsp (1.5 ml)	Salt
1 tsp (5 ml)	Olive oil

1. In a large bowl dissolve sugar and yeast in warm water. Let stand 5 minutes.
2. Stir in 2-3/4 cups (680 ml) flour, salt and oil to form a soft dough.
3. Turn dough out onto a lightly floured surface. Knead until smooth and elastic (about 5 minutes)
4. Add enough of remaining flour, 1 tablespoon (15 ml) at a time to prevent dough from sticking to hands.
5. Place dough in a bowl coated with cooking spray, turning dough to coat top.
6. Cover dough and let rise in a warm place (85°F/30°C), free from drafts, 1 hour or until doubled in size.
7. Punch dough down and divide in half.
8. On a lightly floured surface, roll out each half into a 12" (30 cm) circle.
NOTE: Transfer to a cookie sheet or pizza peel before adding toppings.
9. Crimp edges of dough with fingers to form a rim.
10. Cover and let rise in a warm place (85°F/30°C), free from drafts for 30 minutes.

11. Top with your favourite ingredients and follow the directions in the 'How to Use' section. Bake until cheese is bubbling and crust is golden brown.

Yields: 2 – 12" (30 cm) pizza crusts

Whole Wheat Pizza Dough

1 tbsp. (15 ml)	Sugar
1-1/4 cups (310 ml)	Warm water (110°F/45°C)
1 pkg.	Active dry yeast
1-1/4 cups (310 ml)	All-purpose flour
2 cups (500 ml)	Whole wheat flour
1 tsp.	Salt
2 tbsp. (30 ml)	Olive oil

1. Dissolve sugar and yeast in water and allow to sit for approximately 5 minutes until foamy.
2. In a separate bowl, combine all-purpose and whole wheat flour
3. Remove 1/4 cup (60 ml) of the flour mixture and put aside.
4. Add salt to the 3 cups (750 ml) of flour
5. Pour the yeast mixture and oil over the flour/salt mixture
6. Stir until mixed then knead, gradually adding remaining flour mixture until dough is no longer sticky
7. Turn dough onto a floured surface and knead for about 10 – 15 minutes
8. Shape dough into a ball and transfer to a large bowl. Cover with a damp towel and allow the dough to rise in a warm location until doubled in size.
9. Punch dough down and divide in half
10. Shape dough into a 12" (30 cm) circle.
NOTE: Transfer to a cookie sheet or pizza peel before adding toppings.
11. Crimp edges of dough to form a rim.
12. Allow dough to rest for 15 minutes
12. Top with your favourite ingredients and follow the directions in the 'How to Use' section. Bake until cheese is bubbling and crust is golden brown.

Yields: 2 – 12" (30 cm) pizza crusts

Four Cheese Pizza

1	Pizza Crust (see recipes above)
1 cup (250 ml)	Pizza sauce
4 oz. (112 g)	Mozzarella cheese, grated
3 tbsp. (45 ml)	Parmesan cheese, grated
4 oz. (112 g)	Emmental Cheese, grated
4 oz. (112 g)	Gorgonzola cheese, sliced
1 tbsp. (15 ml)	Olive Oil
	Red pepper flakes (optional)

1. Spread the surface of the pizza crust with pizza sauce. Sprinkle with red pepper flakes (optional).
2. Spread the Mozzarella, Parmesan and Emmental cheeses. Top with slices of Gorgonzola. Drizzle with olive oil.
3. Follow the directions in the 'How to Use' section.

Sausage Pizza

1	Pizza Crust
1 cup (250 ml)	Pizza sauce
1/2 tsp. (3 ml)	Fennel seeds
1/2 lb. (225 g)	Italian sausage, cooked and cut into small pieces
1 cup (250 ml)	Green pepper, chopped
2 cups (500 ml)	Provolone cheese
2 cups (500 ml)	Mozzarella cheese

1. Spread pizza sauce on crust. Sprinkle the fennel seeds.
2. Spread sausage, green pepper, provolone and mozzarella cheese.
3. Follow the directions in the 'How to Use' section.

A short supply cord is provided to reduce the hazards of becoming entangled in or tripping over a long cord. Extension cords may be used if care is exercised in their use. If an extension cord is used, the marked electrical rating of the detachable power-supply cord or extension cord should be at least as great as the electrical rating of the appliance. If the appliance is of the grounded type, the extension cord should be a grounded 3-wire cord. The extension cord should be arranged so that it will not drape over the counter top or table top, where it can be pulled on by children or tripped over.

LIMITED WARRANTY

Salton Canada warrants that this appliance shall be free from defects in material and workmanship for a period of one year from the date of purchase. During this 'in-warranty' period, defective products will be repaired or replaced at the discretion of the retailer and/or Salton Canada. A defective product should be returned to the original place of purchase within the retailer's stipulated return/exchange period*. If you do not wish or are unable to have a defective product replaced under warranty by the retailer, Salton Canada will repair or replace the defective product without charge. You may contact us for assistance by mail, e-mail, fax or telephone as listed below.

This warranty covers normal domestic usage and does not cover damage which occurs in shipment or failure which results from alteration, accident, misuse, abuse, glass breakage, neglect, commercial use or improper maintenance.

To ensure prompt 'in-warranty' service be sure you have an original proof of purchase. You may be asked to return the product to us along with a description of the defect and your address, zip/postal code.

For repairs not covered by the warranty, please contact us for assistance.

salton[®]

SALTON CANADA

Customer Service Department
81A Brunswick, Dollard-des-Ormeaux
Quebec Canada H9B 2J5
website: www.salton.com

E-mail: service@salton.com
Fax: 514-685-8300
Tel: 514-685-3660

* Return/exchange policies at each retailer vary and may differ from the Salton Canada 1 year limited warranty period.